



Supply List

Before beginning cart assembly, ensure that all of the following components and fasteners are included in the package.

Parts:

1. Handle
2. Base
3. Short Support with Caps
4. Short Support without Caps
5. Tall Support with Caps (2)
6. (8) 3/8-16 X 3/4" Socket Head Bolts (may already be pre-installed on Cart Base)
7. (2) 5" Swivel Caster (pre-installed on Cart Base)
8. (2) 5" Fixed Caster (pre-installed on Cart Base)

Tools Required:

1. 5/16" Hex Wrench (included)

Notes:

1. We recommend at least two people assemble this cart.
2. DO NOT tighten bolts until cart is completely assembled, this allows for adjustment, if necessary.
3. All bolts should be kept tight for the cart to function properly and to avoid a potentially dangerous situation.

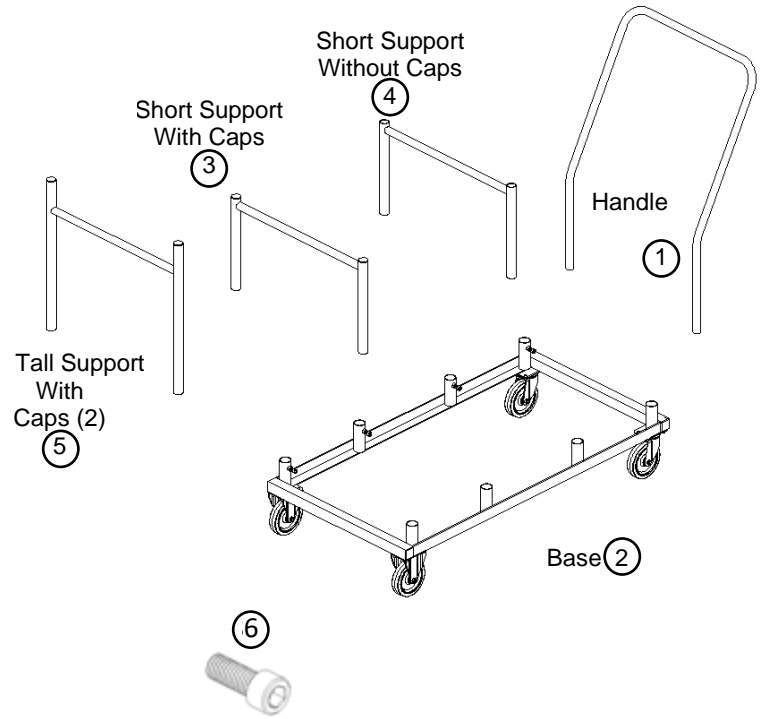
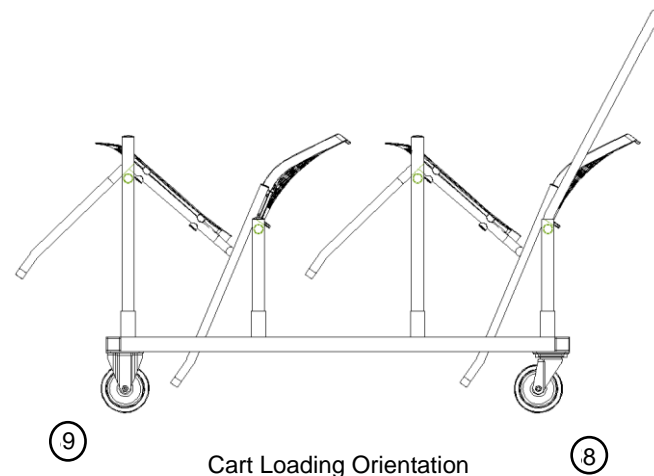
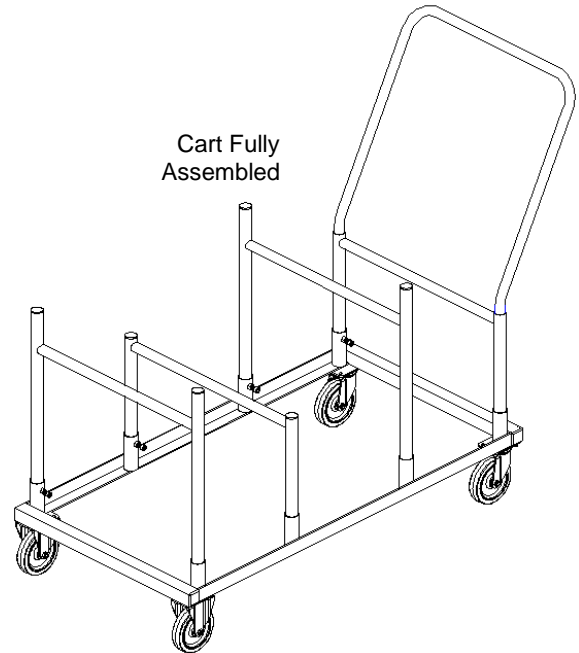

See other side for assembly instructions

Assembly Instructions

Step:

1. Place the Base down so that the casters are on the floor.
2. Insert the Short Support without Caps into the sockets on the SWIVEL caster end of the Base (See Figure 1).
3. Insert the Handle into the Short Support without Caps (See Figure 2).
4. Insert one Tall Support with Caps into the sockets on the FIXED caster end of the Base & one into the sockets near the Handle of the cart (See Figure 3).
5. Insert the Short Support with Caps into the remaining Base sockets (See Figure 4).
6. Tighten all bolts, securing handle & supports in place.

