



Durable Lightweight Tables & Chairs

SwiftSet Folding Chair Cart-Flat

ASSEMBLY INSTRUCTION SHEET

Supply List

Before beginning cart assembly, ensure that all of the following components and fasteners are included in the package.

Parts:

1. Base Assembly
2. Stack Guide (Left & Right) (2)
3. Handle
4. Nylon Strap
5. (4) 3/8"-16 X 5/8" Socket Head Bolt
6. (2) 3/8"-16 X 1 1/2" Socket Head Bolt
7. (1) 5/16"-18 X 1 1/4" Hex Bolt
8. (2) 5/16" Flat Washer
9. (1) 5/16"-18 Nyloc Nut

Tools Required:

1. 1/2" Wrench/Ratchet & Socket (not included)
2. 5/16" Hex Wrench (included)

Notes:

1. We recommend at least two people assemble this cart.
2. DO NOT tighten bolts until cart is completely assembled, this allows for adjustment, if necessary.
3. All bolts should be kept tight for the cart to function properly and to avoid a potentially dangerous situation.

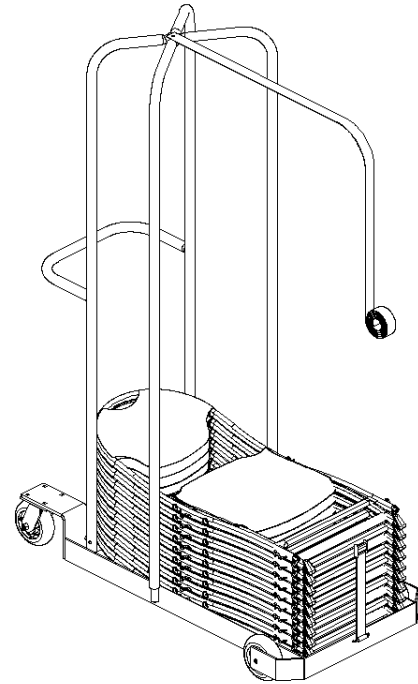

Load chairs as shown. Place the strap over the chair stack and insert the strap end through the buckle at the bottom, front of the cart. Keep the strap tight while cart is in motion.

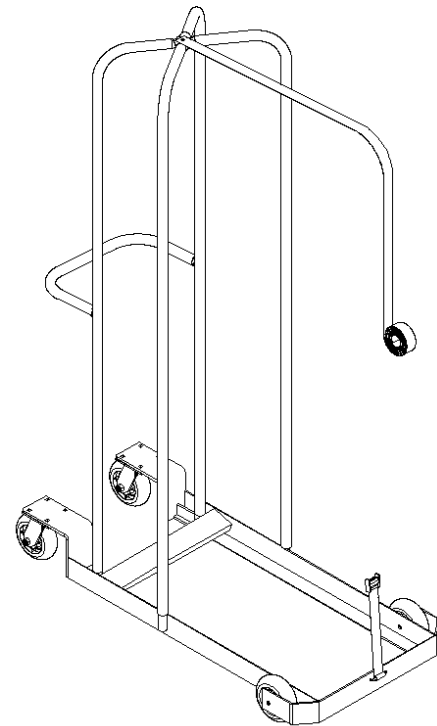
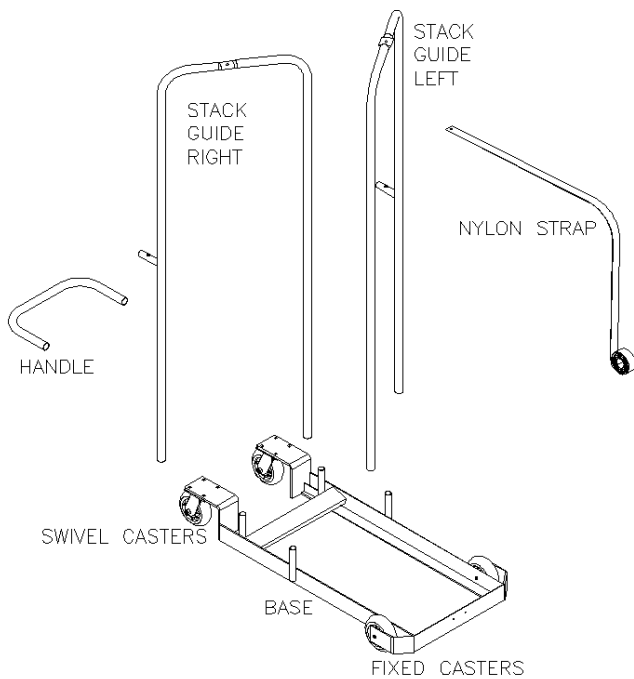

See other side for assembly information

Assembly Instructions

Step:

1. Attach the Stack Guides to the Base (See Figure 1 & 2) by sliding the Stack Guides over the stack guide posts. Make sure the Handle Posts on the Stack Guides face the rear of the cart (swivel casters). Start the 3/8" X 5/8" socket head bolts into the threaded holes on the Stack Guides (if not already done). Do not tighten yet.
2. Slide the Handle over the handle posts located on the Stack Guides (See Figure 3). Make sure the threaded holes in the bottom of the Handle line up with the holes in the Handle Posts (See Figure 3, Detail A). Insert the 1 1/2" long, 3/8" bolts. Do not tighten yet.
3. Bolt the Stack Guides together at the top. Insert the 1 1/4" long, 5/16" bolt through the underside of the Stack Guides, place a washer on top of the Stack Guides, followed by the strap, another washer, and the nut (See Figure 4, Detail B). Do not tighten yet.
4. Check the alignment of the Stack Guide assembly from the front and side of cart. It may be necessary for a second person to hold the Stack Guides perpendicular to the cart base while the remaining bolts are tightened.
5. Tighten all bolts.

